

Theatre World Backdrops

BACKDROP CARE & MAINTENANCE

Dear Valued **TheatreWorld** Customer,

TheatreWorld Backdrops is pleased to assist you in putting on a quality production through the rental of our backdrops, headers, leg packages, etc.

Proper maintenance and care is imperative while using **TheatreWorld** backdrops and drapery products. Correct handling procedures ensure that the drop(s) will stay in top condition and that the chances of chargeable damage will be minimized. Your team/associates should have the proper knowledge and skill to handle and care for your scenic rental. In order to further avoid costly damage and to ensure you derive the most enjoyment from your backdrop or show package, please take the time to read and adhere to the following instructions. If you have any questions or comments about your rental backdrops, please contact our customer service team at 1.877.901.3353 or 1.855.892.3767 (1.855.TWB.DROP). **Please note, this document is also available online in our "Rental Info" section for your convenience.**

- UPON RECEIVING YOUR BACKDROP
- BACKDROP UNFOLDING
- HANGING AND USING THE BACKDROP
 - How a Backdrop Hangs
 - Systems for Hanging
 - Hanging a Backdrop from a Curtain Track
 - Hanging a Backdrop from a Fly System
 - Hanging a Backdrop from a Dead Hung System or a Pipe and Drape System
 - Pipe Pocket
 - Steaming a Backdrop
 - Modifying the Backdrop for Your Use
 - Lighting a Backdrop
 - Outdoor Use
- BACKDROP RETURN
- STEPS FOR FOLDING/RETURNING THE BACKDROP
- POSSIBLE PROBLEMS YOU CAN AVOID – AKA "NOT NORMAL WEAR"
- I'M SORRY, THE BACKDROP GOT TORN! WHAT DO I DO NOW?
- FINAL NOTE

UPON RECEIVING YOUR BACKDROP

Please note that your backdrop comes folded in a protective cotton travel bag. Please store in a safe place—perhaps the box that you will be returning it in—as this travel bag will be reused when you return the drop.

BACKDROP UNFOLDING

Make sure the floor is clean and debris-free (covered if necessary, swept, mopped, and clear of liquid, sharp objects, and other clutter) to ensure that the backdrop will remain clean and undamaged. Remove the backdrop from the box and examine it for any obvious shipping damage. Take note of the exact way it is folded. You will want to remember this so you can duplicate it after the drop is used and you are ready to pack it up—however, for your benefit, step-by-step instructions have been included below. We recommend moving all set pieces away from the area where you are unfolding, mounting, and refolding the backdrop.

HANGING AND USING THE BACKDROP

How a Backdrop Hangs:

Approximately every 12" along the top edge of the backdrop, there is a pair of tie lines, each about 12" long, which give support to the backdrop. We have included additional tie lines in your *white Important Document envelope* for your convenience, should any of the currently-attached lines need to be replaced.

**Make sure that all set pieces are a minimum of 12" away
from the backdrop at all times!**

Systems for Hanging:

The type of **support rigging** in your facility will determine how the backdrops are secured. They will either be rigged to a *fly* system, a *dead hung* system, or you will need a *pipe and drape* system.

- A fly system means that the batten (typically steel pipes) raises and lowers using a series of ropes, pulleys, and counterweights or motors. This allows the backdrop to be hung easily and safely.
- A dead hung system means that the battens are fixed near the ceiling and do not move. A task/OSHA-approved ladder or lift must be employed to install the backdrop.
- A pipe and drape system is commonly used by **event companies or companies that don't have any rigging** above their performance space. The pipe and drape system is a series of upright and crossbar metal pipes that connect and create a rectangular frame with large metal "feet" or bases that keep the structure vertical. A task/OSHA-approved ladder or lift must be employed to install the backdrop. (These can be rented from local event companies in your area.)

Hanging a Backdrop from a CURTAIN TRACK:

Slip one of the tie lines through an eyelet or a chain link on the track carrier. Then, tie the two lines into a bow, allowing one set of tie lines per carrier. ***Make sure someone is relieving the weight of the backdrop while you are tying the lines to the eyelet system.***

Hanging a Backdrop from a FLY SYSTEM:

Lower your pipe batten to approximately 3' from the floor. Start in the **center** of the backdrop, which is denoted with a **white string**. Begin working your way out, tying all of the tie lines in a bow (as you would a shoestring). Once every tie line is fastened to the batten, gently push the bows towards the outer edge to make sure they are taut. Then, slowly raise the pipe up off the floor using the system's controls (counterweights or motorized). Make sure you add enough weight to the system to counterbalance the weight of the backdrop and secure the line once the drop is in place.

Hanging a Backdrop from a DEAD HUNG SYSTEM or a PIPE AND DRAPE SYSTEM:

Using an A-frame OSHA approved ladder, or other approved lift, secure the tie lines around the pipe by tying a bow, moving from one end of the pipe batten to the other. Fasten the lines as you would tie a shoestring, lifting and tying as you go. **Have a second or third person on the floor lift the drop to relieve some of the weight.** Allowing the entire weight of the backdrop to hang from a single grommet and tie can cause a tear. If you feel resistance as you lift the backdrop, do not force, jerk, or tug it. Investigate the problem before you continue. Make sure you follow these steps when taking it down as well.

Pipe Pocket:

The pipe pocket is a separate 3-1/2" pocket sewn onto the backdrop, with an opening on either end. It is fully stitched along the top of the pocket and stitched every 12" - 18" along the bottom. The pocket is designed to support hanging-pipes, which are inserted from each end and runs the entire width of the backdrop. Once inserted, the pipes will add weight to the backdrop and help eliminate wrinkles and reduce movement during your production.

The suggested pipe to be used is 1/2" EMT (electrical metallic tubing) with EMT connectors. Rigid pipe may be used for additional weight. (Many who use rigid pipe only put one 10' section in each end of the backdrop.) The 1/2" EMT comes in 8-10 foot lengths and is connected with EMT connectors. These items can be purchased in the electrical department at your local hardware store.

To begin, insert the 1/2" EMT into the pipe pocket. You need more than one person for this operation. Applying duct or gaff tape on the leading edge and all connectors of the EMT will soften sharp edges on the pipe, preventing the tubing from hanging up and tearing the drop. If the tubing does hang up, STOP! Don't force it. Investigate the problem before you proceed.

After inserting your first length of tubing, connect your second length using the EMT connector. Once both pieces of the tubing are in the connector and the screws have been tightened, apply duct or gaff tape around the connector. (Tape should be used on any pipe applications.) This will soften any sharp edges and eliminate hang-ups.

As the pipe is pushed through the pocket, "bounce" the start of pipe along the way to help it avoid snagging.

Once you have inserted the pipe for the full length of the backdrop, place one person on each end and have them firmly pull on either end of the pocket. This is known as "stretching" the drop and can help eliminate wrinkles. Please do not overstretch or aggressively stretch as you can

damage the backdrop. Also remember, if the drop has a chance to "hang" for a while, the majority of wrinkles will disappear naturally. Plan to allow time for the backdrop to settle before opening night.

DON'T FORGET, when taking down the backdrop, first remove the pipe before detaching the backdrop from the batten.

Steaming a Backdrop:

Some backdrops may arrive with slight wrinkling or creasing. While most wrinkles will resolve themselves after the drop has hung for a while, more stubborn creases may require the use of a steamer. A standard commercial steamer with a plastic head is the best tool for this task. (Please do *not* use a steamer with a metal head.) To steam, position yourself on the *back side* (the unpainted side) of the backdrop and carefully run the head of the steamer up and down, working from one side of the backdrop to the other. To avoid costly damage charges, please never apply steam to the painted side of the backdrop and please do not iron your backdrop!

Modifying the Backdrop for Your Use:

- ALTERING THE SIZE FROM THE TOP

TheatreWorld Backdrops strictly forbids altering the backdrop from the top and/or deviating from hanging the drop by the provided grommets and ties for ANY reason. Folding the top and hanging via clamps or any other device compromises the security of the backdrop and significantly increases your chances of damaging it and incurring repair or replacement fees, which can be costly.

- ALTERING THE SIZE FROM THE SIDES

In the event the backdrop is too wide, simply fold back the side (or sides) of the backdrop that you wish to hide and tie the lines to the batten.

- ALTERING THE SIZE FROM THE BOTTOM

Clean the stage under the backdrop or add a plastic drop cloth underneath and then fold the bottom portion of the backdrop up and behind. Fold as concisely and neatly as possible, keeping the painted side interior to the fold. A pipe can be laid on the back side (unpainted side) of the backdrop for weight. Backdrop movement may damage the painted area of the backdrop if you fail to provide a protective barrier.

Lighting a Backdrop:

Lighting instruments should distribute a general, even light over the surface of the backdrop and eliminate shadows from any wrinkles or unevenness on the surface. Try using different colored gels or lights to create drama and effects on the backdrop. Please note that backlighting will not work as the backdrops are opaque. All backdrops are hand-painted muslin canvas and not see-through like a cyclorama or scrim. **Be sure to place the backdrop at a minimum of 24" from any incandescent lighting source, such as a lamp or PAR can.** LED lights and low-heat emitting lights should be placed a minimum of 8" away from the backdrop.

Outdoor Use:

TheatreWorld Backdrops prohibits the use of any of our backdrops for outdoor events without a review with our technical team prior to rental. Backdrops hung outside are prone to water damage and humidity from the elements and has a tendency to catch wind like a sail. This can cause devastating damage to objects around the drop, bodily injury, and/or damage to the backdrop itself.

BACKDROP RETURN

When removing the drop, remember to clean and prepare your work surface before you lower the drop. **DO NOT REMOVE** the backdrop while set pieces are still on stage. Start by lowering the backdrop to working height and **REMOVE** all pipes from the pipe pocket. Carefully untie or remove the drop from its attachments and lay it out for folding. **DO NOT CUT THE LINES.**

Once the drop is laid out on a clean surface, two people can carefully refold the drop back into a small rectangular form and roll it (where applicable) for insertion into the cotton travel bag.

STEPS FOR FOLDING/RETURNING THE BACKDROP

1. Lay backdrop on a clean, smooth surface with the painted side up.
2. Fold the backdrop in half widthwise.
3. Continue to fold the drop in half widthwise, using the parallel fold method, until it is approximately 36" wide and 6 grommets are showing at the top.
4. Fold the remaining amount by **thirds**, starting with the right side, then the left.
5. Roll the backdrop from the bottom up to the top evenly and smoothly in a "rolled sleeping bag" fashion until the drop is fully rolled to the top.
6. Re-tie the support string around the rolled backdrop.
7. Replace the drop into the cotton travel bag.
8. Place the backdrop back into the original box.
9. Seal the box properly with packing tape.
- 10. Place the return shipping label directly on top of the old shipping label.**
11. Take the box to a UPS location, unless you have requested for TheatreWorld to schedule a UPS pick-up for you or you have a regularly scheduled UPS pick-up at your location.

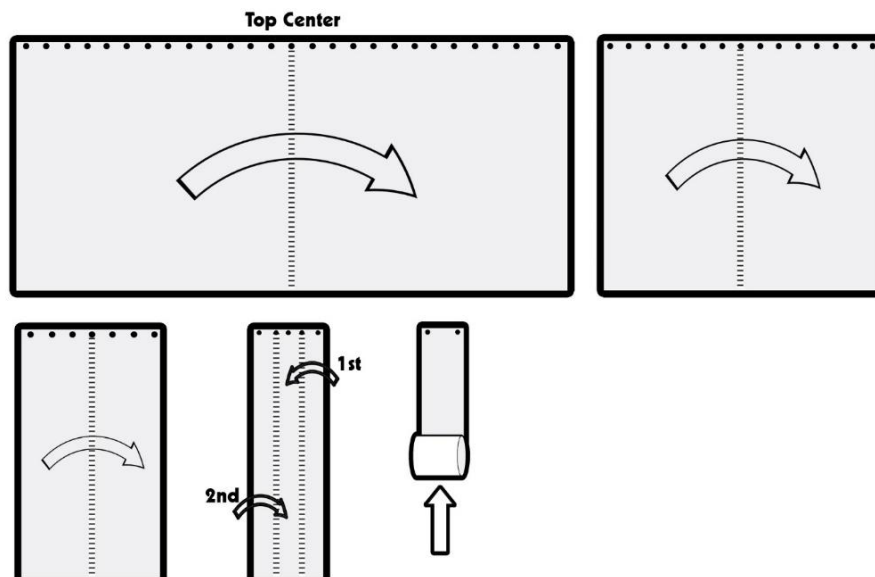

POSSIBLE PROBLEMS YOU CAN AVOID – AKA "NOT NORMAL WEAR"

TheatreWorld Backdrops has provided the following tips to help you avoid costly repairs or problems. We would like to stress the importance of taking a moment to go over these DOs and DON'Ts with your team. If you have used backdrops and draperies before, you have undoubtedly encountered some or all of these potential hazards. Above all else, just use common sense. If you and your group/company employ the following principles, you will get the maximum enjoyment out of your backdrop.

- 1. RIPS AND TEARS:** Avoid dragging the backdrop as much as possible. Make sure your working surface is free of sharp or protruding objects, such as nails, screws, and tacks. If you are hanging the backdrop from a pipe that can be lowered to the floor, have the operator **SLOWLY** raise the drop while others watch for hang-ups. If you are using a ladder to hang the backdrop, confirm that the legs of your ladder are not positioned on the backdrop.
- 2. DO NOT CUT OPENINGS** in the backdrop to support set pieces or create access ports. ***If you cut the backdrop, you will have to purchase the backdrop.***
- 3. HEMMING:** Hemming to alter the size of a backdrop (whether it is from the top, sides, or bottom) shortens the life of the backdrop. Although hemming is a common industry practice, **TheatreWorld Backdrops'** Rental Policy prohibits lessees from altering any items. Should you need to modify the dimensions of your backdrop, please refer to the section entitled "**Modifying the Backdrop for Your Use**".
- 4. STAPLES OR NAILS:** Staples or nails are not appropriate methods to hang a backdrop. If attaching the backdrop to a back wall, rather than a fly system, you may hang the metal grommets on nails as you would a picture frame.
- 5. SET PIECES:** Make sure that ALL set pieces are a minimum of 12" away at all times.
- 6. FOOTPRINTS:** Don't walk on the backdrop.
- 7. TIRE MARKS:** Don't allow any vehicle on the backdrop. Do not roll scaffolding or place a ladder on top of the backdrop.
- 8. DIRT STAINS:** Do not drag the backdrop on its painted surface. ***Never fold or roll the backdrop with the painted surface facing out.*** Make sure the bottom edge of the backdrop is resting on a clean area.
- 9. PAINT STAINS:** If you must paint near a backdrop, be very careful. It is best to hang backdrops after all set pieces have already been painted and are completely dry.
- 10. LIGHTING:** Make sure that **ALL INCANDESCENT (lamps, PAR cans, LEKO's, etc.)** lighting equipment is a **minimum** of 24" away at all times, depending on wattage. LED lights and low-heat emitting lights should be a minimum of 8" away at all times. Avoid hanging lights close to the backdrop.

- 11. BURN MARKS:** Do not iron or apply heat of any kind directly onto the backdrop. Do not drape the backdrop over light fixtures. If lit candles or fire of any kind is present, keep them at a safe distance.
- 12. MODIFICATIONS:** Do not sew or iron any additional materials on to the backdrop. Do not paint or draw on the backdrop. This applies to all mediums, including chalk, pencil, charcoal, markers, pastels, etc.
- 13. TAPE STAINS:** Do not apply tape to the face of the backdrop. Tape leaves a sticky residue and will also remove paint from the backdrop. If using tape to secure something, **ONLY** use blue painter's tape or masking tape.
- 14. FOOD STAINS:** Do not eat or drink near or on the backdrop.
- 15. GREASE/OIL/LIQUID STAINS:** Keep the backdrop away from machinery, forklifts, automobiles, and all liquids. Make sure to keep your working surface free from all of these as well. Check the batten for grease spots and clean thoroughly before attaching the backdrop.
- 16. WATER STAINS:** Do not hang the backdrop in an area where there is a lot of moisture (such as an indoor pool). The fabric will absorb the moisture from the air, which will compromise the integrity of the drop. ***If water gets splashed on the backdrop, IMMEDIATELY dry the area with a fan or hair dryer.*** Make sure the backdrop is completely dry before folding, packaging, and returning it.
- 17. FOG MACHINES:** Fog machines create moisture that, in turn, gets absorbed by the backdrop fabric and reactivates chemicals in the fabric. This leaves unsightly stains that are unable to be covered or repaired. If you are planning to use a fog machine, vent away from the backdrop.
- 18. SMOKE/BUBBLE STAINS:** Smoke (especially black smoke) and soap bubbles will leave a residue on the backdrop. If smoke is present or if bubbles are used, vent away from the backdrop.
- 19. GLUE STAINS:** Do not apply any glue or spray adhesives to the backdrop. Avoid using spray glue near the backdrop, as there is bound to be some "blowback".
- 20. MAKEUP STAINS:** Makeup will stain the backdrop. Please avoid contact.
- 21. GRASS STAINS:** Do not fold the backdrop on a lawn, field, or other grassy area.
- 22. BIRD DROPPINGS/URINE STAINS:** Keep pets and/or livestock away from backdrop. (Have the turtledoves, partridges, and hens in cages and assign a stagehand to walk the camels during the Christmas production!)
- 23. ALL STAINS IN GENERAL:** When you fold and/or roll the backdrop for return, make sure the surface is free of foreign objects like grass, hay, food, bottles, kitchen utensils, etc.

I'M SORRY, THE BACKDROP GOT TORN! WHAT DO I DO NOW?

The most common damage our backdrops incur is unintentional tearing. Although the fabric is quite durable, a backdrop should be handled with the utmost care. If you tear a backdrop, **STOP!** Contact **TheatreWorld Backdrops IMMEDIATELY** for further instructions.

In the event the damage occurs after hours, carefully lower the drop down. Lay the torn portion of the backdrop painted side down on a clean, hard surface. If you are working on carpet, place a piece of plywood or cardboard under the torn area. ***Never apply tape to the face (painted side) of the backdrop—it will remove paint from the backdrop.***

Gently push both sides of the tear together to form a tight seam on the unpainted side of the backdrop. For tears 18" or longer, apply gaffers tape or fabric tape along the length of the seam. You may also have to apply 4" strips of gaffer's tape perpendicular to the tear to keep the seam together. This is especially true of horizontal tears, as they need this extra support to keep the tear from separating. **Do not attempt to glue, sew, or staple the tear together.** We have found that gaffers tape works best. Remember to notify **TheatreWorld Backdrops** of the damage as soon as possible!

FINAL NOTE

We would like to thank you for allowing us to be a part of your event. We strive to make every effort to help you with questions or problems and look forward to many years of supplying you and your team with the highest quality backdrops, headers, stage legs, etc. in the industry.

**BEST WISHES FOR A SUCCESSFUL EVENT/PRODUCTION AND, AS ALWAYS,
THANK YOU FOR CHOOSING THEATREWORLD BACKDROPS.**

